

# Universal Ankle Joint Fabrication Instructions

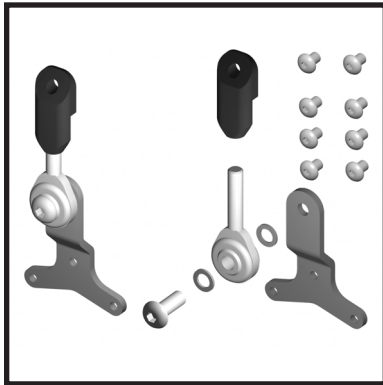

020780 Universal Ankle Joint Pair

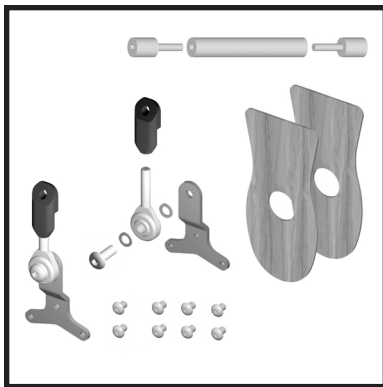

020781 Universal Ankle Joint Pair with Fabrication Kit

## 020781 Universal Ankle Joint Pair with Fabrication Kit

Kit Includes

### 020780 Universal Ankle Joint Pair

- 020784 Stirrup, Universal Ankle Joint, 2 ea.
- 020786 Upper Adjustment, Universal Ankle Joint, 2 ea.
- 020788 Rod End, Teflon lined, Clear Chromate, 2 ea.
- 43005 Flat Washer, 4 ea.
- 880147 10-32x1/2 BHSC Screw, Zn Pltd Alloy Steel, 2 ea.
- 880034 6-32x1/4 BHSC Screw, 18-8 SS, 2 ea.
- 880037 6-32x3/16 BHSC Screw, 18-8 SS, 6 ea.

### 020800 AFO Ankle Joint Fabrication Kit with PolyCar-C™

- 020822 Alignment Screw Kit, 2ea.
- 020818 Alignment Spacer Rod, 1ea.
- 020802 Pre-Cut PolyCar-C™, 2ea.

### Recommended Materials: (Not Included)

- 700-026 Thermo Forming Gloves (Hot Mill Gloves)
- 211045 Teflon 3mm (Sold By Foot)
- 199448 Poly Adhesive
- ZETZ-8 Thermocutter (Hot Knife)
- 187013 Pe-Lite™ or similar pattern material
- 800050 Scalpel Handle
- 800060 Scalpel Blades (150/box, #25, 2")
- 225171 Buffing Cone
- 199905 Nylon Hose (Treated)
- 227305 Mobile Vacuum Unit or Equivalent
- 226225 Cast Saw
- Sand Paper

## Fabrication of Articulating AFO Reinforced with PolyCar-C™

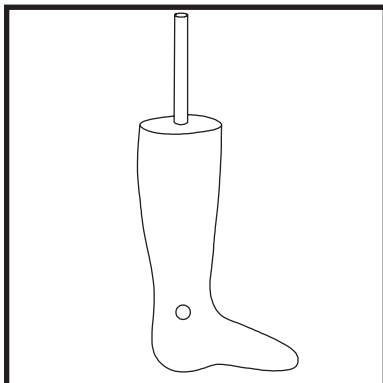

Figure 1: Positive Cast

1. Cut the alignment rod to provide a minimum of 3/16" ankle clearance per side, and place it in the negative cast. Pour the plaster cast as shown in Figure 1.
2. Substitute the two alignment screws for the ankle joint screws for positioning of joints on alignment rod as shown in Figure 2.
3. Contour the stirrups to the cast. Fill in any remaining space with plaster or Pe-Lite™. This will provide intimate contact with the cast during vacuum forming.
4. Cover the cast with nylon hose and make openings in the hose to provide access to the holes of the alignment rod.

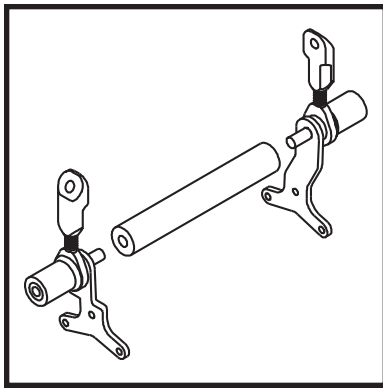

Figure 2: Ankle Joint Assembly with Alignment Kit

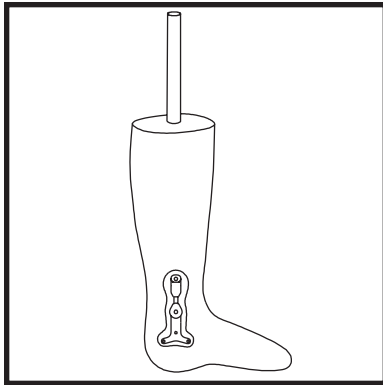

Figure 3: Outline of PolyCar-C™

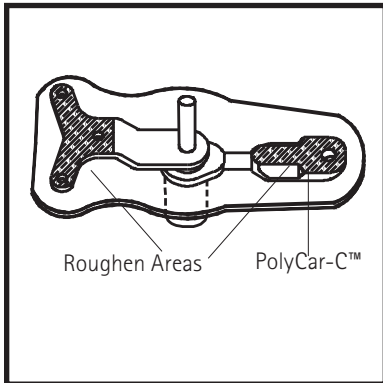

Figure 4: PolyCar-C™ Placement

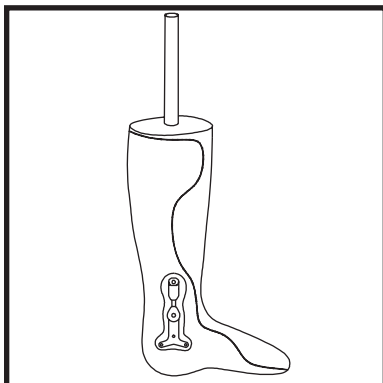

Figure 5

5. Cut two (2) pieces of teflon sheeting 3/4" oversize using the supplied precut PolyCar-C™ as a pattern. Cut the 3/4" hole in the Teflon to match the precut PolyCar-C™.
6. Outline the PolyCar-C™ pattern on the cast as shown in Figure 3. Coat this area with Poly Adhesive.
7. Roughen underside of the ankle joint with sand paper as shown in Figure 4. Clean both ankle joints and PolyCar-C™ with a solvent or alcohol to remove dirt and oil.
8. Place plastic, polypropylene or copolymer, along with metal components in an oven at 400 degrees for 5-7 minutes. Place precut PolyCar-C™ in oven resting on separate teflon cutouts.
9. The PolyCar-C™ will appear soft and glazed when it is ready for molding and bonding. (Caution: The PolyCar-C™ will not bond if it gets too hot). After the PolyCar-C™ and ankle joint assemblies are heated sufficiently, position the ankle joint assembly on the PolyCar-C™ as shown in Figure 5. Leave in oven for 1-2 additional minutes.
10. Using hot mill gloves, place the heated PolyCar-C™ ankle joint assembly on the outlined cast and press the edges firmly to the cast using the teflon cutouts. Next, vacuum form the plastic. (Caution: Since good adhesion depends on adequate temperature, speed during this step is essential).
11. Once the plastic has cooled, remove the plastic covering the alignment screw heads. With a cast saw rough trim the AFO following the desired anterior and posterior trimlines with exception of the area around the joints. Figure 5. (Caution: Care must be taken to avoid hitting the ankle joint or stirrup with the cast saw or other metal objects).
12. Remove both alignment screws and draw trimlines just above the alignment screw on both medial and lateral upper sections of the of the ankle joints and at the apex of the lower section of the joints as shown in Figure 6. Extend all trimlines continuously from medial to lateral.

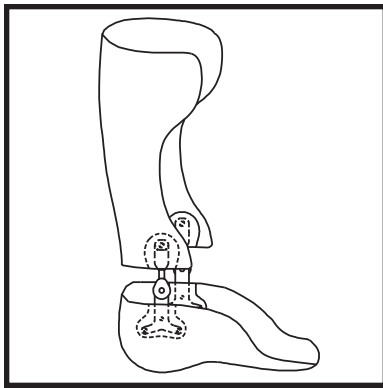

Figure 6: Additional Trimlines

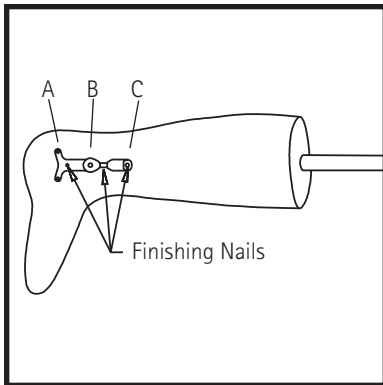

Figure 1b

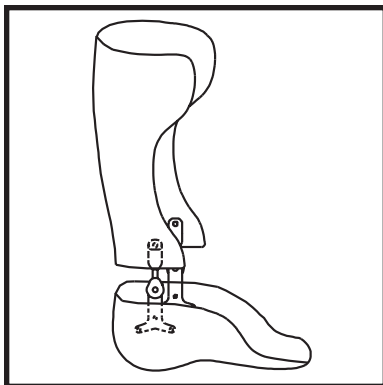

Figure 2b

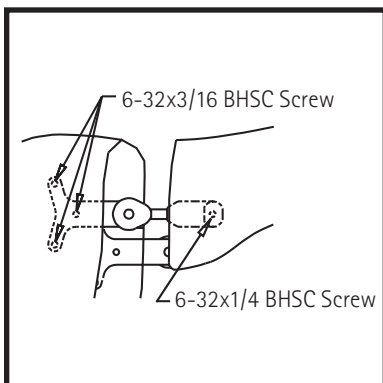

Figure 3b

13. Use thermocutter (hot knife) to cut around the joint area and through the PolyCar-C™. Remove the AFO from the cast and nylon hose and use the thermocutter as needed on the inside of the AFO.
14. Separate the proximal and distal sections of the AFO and finish the edges with a buffing cone. Use a scalpel blade and fine sandpaper to remove rough edges around the PolyCar-C™.

### Fabrication of Articulating AFO without PolyCar-C™

1. Modify cast. (Note: Prior to installation of ankle joint it may be necessary to modify the cast to obtain proper alignment.)
2. Contour ankle joint stirrups for desired fit.
3. Cover the cast with nylon hose. Determine the proper axis and position of the ankle joint and outline joint location on cast.
4. If an "Alignment Rod" is not used, locate the holes in the ankle joint assembly as shown in Figure 1b and place small finishing nails in the cast at these locations. If an "Alignment Rod" is used; the finishing nails are only needed in holes "A" and "C".
5. Place the plastic polypropylene or copolymer together with ankle joint assemblies in an oven at 400 degrees.
6. When the plastic is ready for forming, remove the ankle joint assemblies and using the finishing nails, anchor the joints on the cast. Form the plastic as usual.
7. Once the plastic has cooled, using a cast saw rough trim the AFO using standard anterior and posterior trim lines with exception to the area around the joints. (Caution: Care must be taken to avoid hitting the ankle joint or stirrup with the cast saw or other metal objects.) Use a hot knife (thermocutter) to cut through the plastic overlapping the ankle joint as shown in Figure 2b.
8. Remove the AFO and nylon hose from the cast and use a thermocutter as needed to trim the inside of the AFO.
9. Use a small punch or heated metal rod to gain access to the screw holes shown in Figure 3b. Take care to not cross thread the screws.
10. Separate the proximal and distal sections of the AFO and finish the edges with a buffing cone.

## Instructions to the Practitioner

The practitioner should discuss indications, contraindications, care, maintenance, and application instructions with the patient and/or caregiver before use. In choosing the appropriate joint and designing the orthosis, the practitioner should consider many variables including, but not limited to, the patient's weight, activity level, ambulation characteristics, muscular control, environment and risk of injury due to failure.

### Indications

- Applications where adjustment of subtalar joint alignment is desired
- Applications where ankle support and free plantar/dorsiflexion is desired

### Contraindications

- Patients with poor or absent plantar/dorsiflexion control
- Metal KAFO's
- AFO's intended to provide torsion control
- RGO's

Caution regarding anterior and posterior stops: Stops are not contraindicated. Orthoses fabricated with a stop, especially an anterior stop, generate higher loads on an orthotic ankle joint than free motion orthoses. An increased risk of failure (e.g. pullout from the plastic, device breakage, etc.) is inherent with these higher loads. The practitioner must determine if the increased risk of failure poses an unacceptable risk of injury to the patient.

### Daily Care and Maintenance

The patient or guardian should:

- Have orthotist check orthosis on a quarterly basis or if joints are dirty or rusty, screws are loose, straps torn or worn, or if the orthosis is damaged in an accident.
- Inspect the components for dents, scratches, cracks or corrosion.
- Inspect the straps for tears or damage.
- Keep the joint clean and free of debris for the best performance. Clean metal components with a dry, lint free cloth and clean plastic and leather with a soft cloth and mild soap.
- Avoid humid or wet environments and always dry the joints and strapping thoroughly should they get wet.
- Contact their practitioner should they have any questions or concerns.

### Fabrication Guidelines

- A skilled technician must perform fabrication of the orthosis.
- Do not modify the ankle joint mechanism in any way.
- Use a thread locker to secure all threaded fasteners excluding the rod end.
- This device is intended for single patient use.

Failure to follow these guidelines or use as indicated will void any warranty.