

External Clutch Lock



140100 External Clutch Lock Kit

- Rated to 300 lbs.

External Clutch Lock Assembly
140100

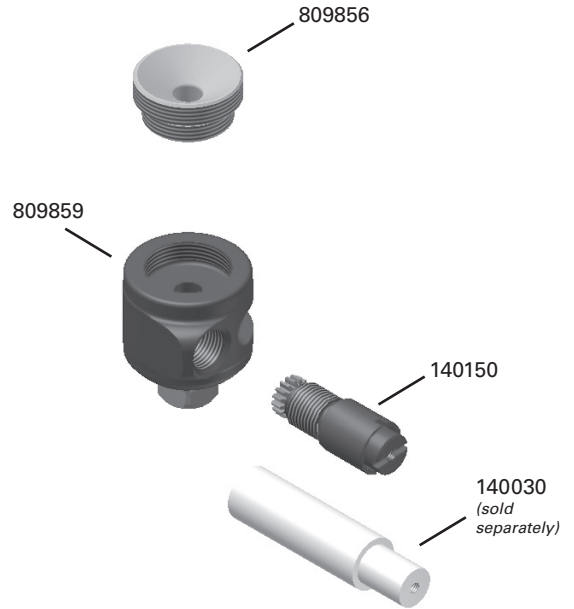

External Clutch Lock Kit:

140100	External Clutch Lock
	<i>Kit Includes:</i>
809859	External Clutch Lock Body w/Pyramid
140150	Clutch Assembly w/Air Expulsion
809856	External Clutch Lock Threaded Adapter

Plungers: (sold separately)

140040	2" Clutch Lock Plunger, 1/4"-20 Thread
140041	1-1/2" Clutch Lock Plunger, 1/4"-20 Thread
140043	2" Clutch Lock Plunger, M10 Thread
140044	1-1/2" Clutch Lock Plunger, M10 Thread

Fabrication Kits: (sold separately)

809880	Fabrication Kit F/Ext Locks
	<i>Kit Includes:</i>
809882	Fabrication Dummy Body F/Ext Locks
809883	#6-17 x 1 1/4" FLT HD Drywall Screw
809881	Fabrication Dummy Lid F/Ext Locks

Push Button Extension: (sold separately)

140030	Push Button Extension
---------------	-----------------------

Fabrication Kit
809880

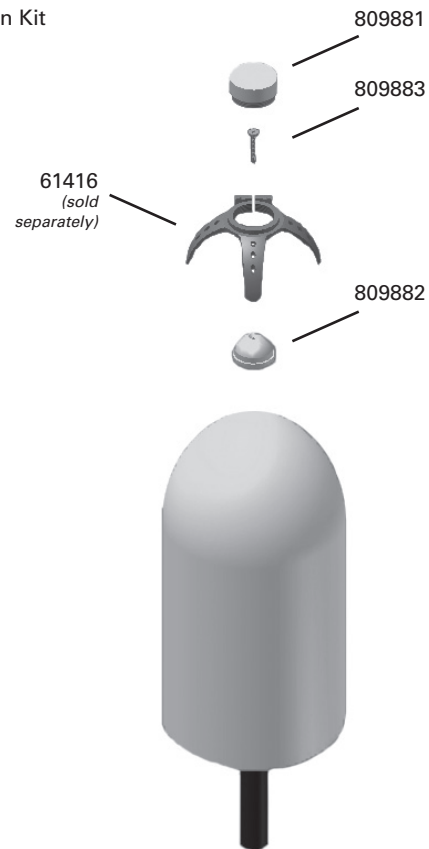

Fillauer LLC

2710 Amnicola Highway • Chattanooga, TN 37406 USA • Tel: 800.251.6398 • Fax: 423.629.7936 • www.fillauer.com
Centri® • Kung Hans Väg 2 • 192 68 Sollentuna, Sweden • Tel: +46 8 505 332 00 • Fax: +46 8 505 332 05 • www.centri.se

Mold Preparation

Prepare the mold as normal using custom modifications to accommodate patient's functional goals.

Place the alignment dummy on the center line of the model and attach using the attachment screw provided. Blend the distal end of the model to the inner flair of the dummy with plaster slurry. Remove dummy for installation after PVA bag is applied.

Lamination

Apply inner PVA bag and cap end to enclose plaster cast. Apply a coat of stick wax (p/n 990035) to the thread of the lamination dummy and pack the inside of the dummy cap with wax to prevent resin contact. Apply the dome part of the dummy kit (p/n 809882) without threads over the PVA bag and reattach using the attachment screw provided.

Apply appropriate reinforcement materials to the model to create a sufficient base layout and foundation based on patient weight and activity level.

Thread fabrication dummy lid (p/n 809881) into three prong lamination anchor. Place lamination anchor on top of fabrication dummy body (p/n 809882). Align as desired.

Based on patient weight and activity, apply outer reinforcement materials over the adapter (which should include layers of carbon and glass) to provide reinforcement.

Finish adding any other lamination materials to custom accommodate the patient's weight and activity level by selecting and adding the appropriate stockinettes and strengthening fabrics.

Apply the outer PVA bag.

The selected resin should be prepared and poured into the outer PVA bag and thoroughly saturated around the adapter and fabrication dummy.

Be sure to tape off any excess resin from around the dummy to ensure that the dummy is not completely enclosed in resin. This will assist in easy removal.

Assembly

After resin has set and socket is forming, remove the tape and outer PVA bag.

Grip the fabrication dummy and unthread it from the adapter. If needed, remove any excess resin by grinding around the adapter.

With a screw driver, remove the dome attachment screw from the inner fabrication dome.

Remove and trim the socket to the desired trim lines to meet the patient's needs. Install the external clutch lock w/pyramid (p/n 140100) and secure using set screw on anchor along with manufacturing recommendations.

Fabrication Guidelines

A trained technician must perform fabrication of the prosthesis.

Do not modify the housing or the locking mechanism in any way.

Use Loctite to secure all threaded fasteners.

Applying more torque than recommended may cause the lock to malfunction.

Fabrication of a socket should be done using a fabrication kit (p/n 809880) including fabrication dummies.

Inspect operation of mechanism after installation into the socket.

Daily Care and Maintenance

The Prosthetist should discuss the following inspection procedures and guidelines with the patient.

Check the locking mechanism for proper operation before each use. Discontinue use of prosthesis and contact your Prosthetist if locking mechanism is not performing as expected.

A minimum of three plunger serrations should be engaged for secure use.

Avoid bumping the button to prevent accidental unlocking. This risk increases if the Button Shield is not utilized during fabrication.

Keep the lock clean and free of debris for the best performance and proper lock engagement.

Avoid humid or wet environments and always dry the components should they get wet. Prolonged exposure to moisture can cause metal components to corrode and fall prematurely.

Should the lock malfunction in any way (e.g. accidentally disengage, fail to release, etc.) discontinue use of the lock immediately and contact your Prosthetist.

Contact your Prosthetist should you have any questions or concerns.