



# E-50 Elbow

Product Manual

*Fillauer*®



# Contents

Intended Use.....	5
Warnings and Precautions .....	5
Qualified Provider .....	6
Specifications and Preparations Before Use (Risk Management for Installation and Calibration) .....	6
Elbow Assembly .....	8
Compatibility.....	10
Disposal / Waste Handling .....	10
Warranty .....	10
User Instructions .....	11
Serious Incidents .....	11

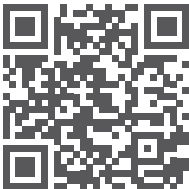

To see other language options, visit [fillauer.com](http://fillauer.com).



# Intended Use

The E-50 elbow, appropriately sized for children, is used with any transhumeral or higher upper extremity prosthesis. This elbow unit features multiple body-powered locking positions and comes in a variety of color configurations. It includes adjustable-friction axial rotation through the proximal turntable and can be purchased with or without a **forearm section** (see prefabricated forearm table).

## Performance Characteristics

	E-50 Elbow
Weight	<b>7 oz. (198 g)</b>
Yoke	<b>Aluminum</b>
Locking Positions	<b>10</b>
Saddle	<b>Single Thickness Stainless Steel</b>
Primary Materials	<b>Stainless Steel, Steel, Aluminum</b>

This device is intended for single patient use only.

## Storage and Handling

It is recommended that prosthetic elbows be stored in a cool, clean, dry environment away from harsh chemicals (chlorine, acids, acetone, etc.).

# Warnings and Precautions



**NOTICE:** An upper-limb prosthetic device user's ability to drive should be determined on a case-by-case basis by a specialist. Contact your local governing authorities regarding any driving restrictions or limitations.



**WARNING:** Body-powered devices should not rely on cable tension for grasp control if the user has been cleared to drive with the prosthesis. Failure to maintain tension while controlling the steering wheel could cause serious injury or death.



**NOTICE:** To prevent malfunction of the elbow, the instructions below on trimming the lock cable and housing must be followed. Failure to do so will likely result in immediate or premature failure that will not be covered under warranty of the device.



**CAUTION:** Abnormal or improper environmental conditions will lead to malfunctioning and damage of the prosthesis and are not covered under the warranty of the device. This prosthetic component must not be subjected to dust/debris, liquids, abrasives, vibration, activities which would damage the biological limb, or prolonged extreme temperatures (< -5 °C or > 50 °C). Do not allow debris or liquids to remain in the prosthesis and its components during use. Rinse the device with fresh water and dry immediately after exposure.

## Qualified Provider

Attachment, adjustment, alignment, and delivery of this device must be performed by or under the direct supervision of a qualified prosthetist. Unless stated in this manual, any such activities should not be attempted by the user and will potentially void the device warranty.

## Specifications and Preparations Before Use (Risk Management for Installation and Calibration)

### Alignment

Prosthetic elbows should be aligned to match the natural hanging angle of the contralateral elbow and provide the best possible work envelope for a patient's specific goals. Standard alignment begins at 5 degrees of flexion and the adduction angle should match the hanging angle of the contralateral limb while also allowing midline tasks and reaching the mouth as necessary. The height of the elbow axis may match that of the other arm, but amputees often prefer a slightly shorter prosthetic side for control and weight.

### Installation

- The elbow turntable may be laminated by removing the elbow and cork friction disk from the turntable. They are connected by the  $\frac{3}{16}$  inch slotted nut on the threaded stud visible in the center of the turntable.
- Place the turntable on the distal end of the humeral section mold (beeswax, foam, plaster or similar). A PVA bag should be used to separate the turntable from the humeral mold if foam or plaster are used. Wax the interior surface and the distal face of the turntable.

- Pack any voids between the turntable and mold with silicone fitting gel or similar to prevent it from filling with laminate.
- Mask the turntable distal to the tie-in groove on the knurled ring surface to keep all laminate clear of the distal end.
- Laminate with the appropriate materials for durability and finish as desired by the patient, being sure to tie each structural layer into the tie-in groove in the lamination ring. Carbon fiber tape is a good choice for reinforcing the connection to the lamination ring and is commonly used for distal to proximal strips tied in with circumferential wraps.
- When reattaching the elbow unit, be sure to install the cork disc between the turntable and elbow, and place both washers under the slotted nut before delivery.
- Tighten the nut to set the proper amount of friction with a  $\frac{9}{16}$  wrench.

### Shortening the Cable and Housing

The elbow lock cable AND housing should, in most cases, be adjusted in length to allow smooth and consistent cycling of the lock. To shorten the cable housing, the cable must be pulled out distally and the proximal housing ferrule removed. The housing is then cut from the proximal end. NEVER remove the lock cable housing from the elbow to trim it. The housing has been permanently installed on all elbows. If removed, it must be reattached correctly (threadlocker and mechanically altering the thread), or it will thread into the elbow and cause malfunction of the lock.

The lock cable can be replaced. However, it is recommended that only Fillauer-fabricated lock cables (PN 55705) be used. Other cables and/or their attachment methods can and have caused damage to the lock mechanism which will not be covered under warranty

# Elbow Assembly

- |           |       |                       |            |       |                           |
|-----------|-------|-----------------------|------------|-------|---------------------------|
| <b>A.</b> | 59577 | Yoke Assembly         | <b>T.</b>  | 50740 | Screw                     |
| <b>B.</b> | 50564 | Bolt                  | <b>U.</b>  | 50747 | Hanger                    |
| <b>C.</b> | 50570 | Base                  | <b>V.</b>  | 50427 | Anchor                    |
| <b>D.</b> | 50571 | Screw                 | <b>W.</b>  | 50636 | Spring                    |
| <b>E.</b> | 56111 | Gear Sector           | <b>X.</b>  | 50601 | Cable Guide, E-50A        |
| <b>F.</b> | 55407 | Short Pin             | <b>Y.</b>  | 56191 | Cable Housing, E-50A      |
| <b>G.</b> | 55237 | Long Pin              | <b>Z.</b>  | 50423 | Ferrule, E-50A            |
| <b>H.</b> | 50576 | Cable Pin             | <b>AA.</b> | 56364 | Clear Vinyl Tubing, E-50A |
| <b>I.</b> | 55705 | Cable Assembly, E-50A | <b>AB.</b> | 50634 | Cotter Pin, E-50A         |
| <b>J.</b> | 50560 | Cork                  | <b>AC.</b> | 50745 | Swivel Lever, E-50A       |
| <b>K.</b> | 50559 | Turntable, E-50       |            |       |                           |
|           | 50562 | Turntable, E-50A      |            |       |                           |
| <b>L.</b> | 50561 | Washer                |            |       |                           |
| <b>M.</b> | 50563 | Nut                   |            |       |                           |
| <b>N.</b> | 50600 | Elbow Cap             |            |       |                           |
| <b>O.</b> | 50585 | Long Sleeve           |            |       |                           |
| <b>P.</b> | 50582 | Shaft                 |            |       |                           |
| <b>Q.</b> | 50584 | Short Sleeve          |            |       |                           |
| <b>R.</b> | 50586 | Saddle Assembly       |            |       |                           |
| <b>S.</b> | 50589 | Outside Washer        |            |       |                           |

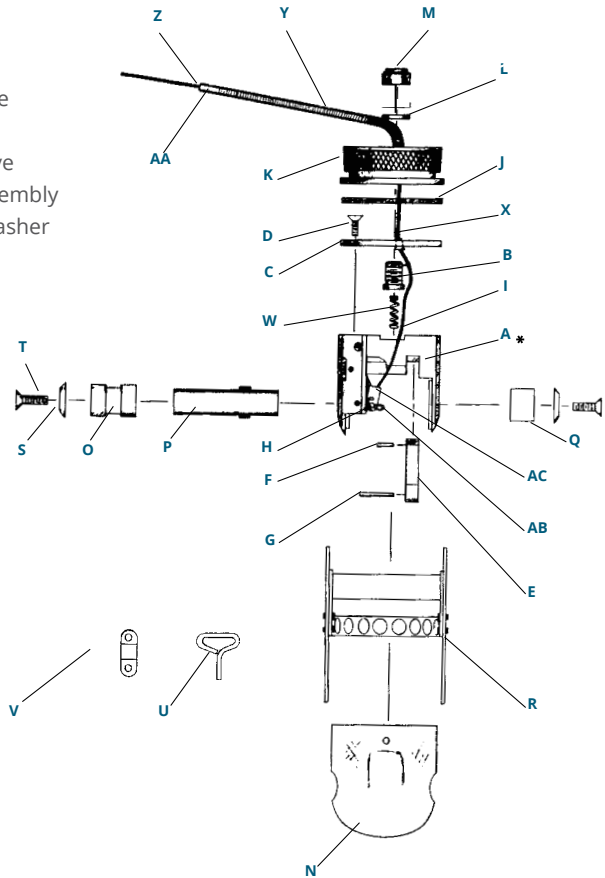



**A. 59577 Yoke Assembly**

- AD. 50565 Yoke
- AE. 56110 Locking Bar
- AF. 50813 Case Pin
- AG. 50573 Cam
- AH. 50629 Spring
- AI. 50572 Cam Bearing
- AJ. 50627 Screw
- AK. 50632 Ratchet
- AL. 50648 Lever Assembly
- AM. 56659 Screw
- AN. 50566 Bushing
- AO. 50567 Bumper
- AP. 50568 Screw
- AQ. 51684 Pin

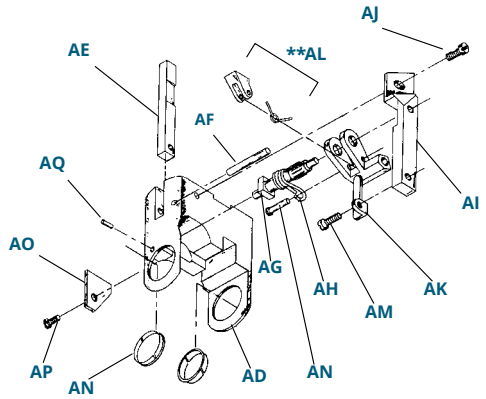

**AL. 50648 Lever Assembly**

- AR. 50630 Pawl
- AS. 50705 Spring
- AT. 50574 Lever
- AU. 50706 Pin

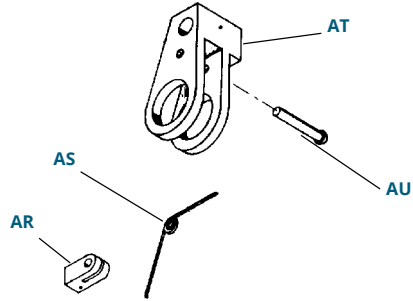

# Compatibility

A Nudge Control (PN 52521 for right and PN 52522 for left) may be used to lock and unlock the elbow when it is not possible through the harness. Lock Cables may be replaced (PN 55705). **Prefabricated Forearms** (see table below) may be used with all E-50 series elbows.

## Prefabricated Forearms

	Tan	Light Brown	Dark Brown	Jet Black
Medium for 1 ½ in. (38 mm) Wrist	57941	57546	57549	57560
Medium for 1 ½ in. (38 mm) Wrist with E-200 Elbow	57540	57505	57508	57565

# Disposal / Waste Handling

The product must be disposed of in accordance with applicable local laws and regulations. If the product has been exposed to bacteria or other infectious agents, it must be disposed of in accordance with applicable laws and regulations for the handling of contaminated material.

All metal components may be removed and recycled at the appropriate recycling facility.

# Warranty

This product has a 12-month warranty against manufacturer defects

# User Instructions

The providing health care professional must review the following information directly with the user.

## Warnings and Precautions for the User



**NOTICE:** The user should monitor their prosthesis daily and contact their health care professional if they experience changes in device performance or if it begins to make noise.



**CAUTION:** All maintenance should be performed by the qualified health care professional.



**NOTICE:** An upper-limb prosthetic device user's ability to drive should be determined on a case-by-case basis by a specialist. Contact your local governing authorities regarding any driving restrictions or limitations.



**WARNING:** Body-powered devices should not rely on cable tension for grasp control if the user has been cleared to drive with the prosthesis. Failure to maintain tension while controlling the steering wheel could cause serious injury or death.



**CAUTION:** Abnormal or improper environmental conditions will lead to malfunctioning and damage of the prosthesis and are not covered under the warranty of the device. This prosthetic component must not be subjected to dust/debris, liquids, abrasives, vibration, activities which would damage the biological limb, or prolonged extreme temperatures (< -5 °C or > 50 °C). Do not allow debris or liquids to remain in the prosthesis and its components during use. Rinse the device with fresh water and dry immediately after exposure.

## Serious Incidents

In the unlikely event of a serious incident, seek immediate medical help and contact your prosthetist at your earliest possible convenience. Clinicians should contact their local Fillauer representative immediately in the event of any device failure.

*Fillauer*®

[www.fillauer.com](http://www.fillauer.com)



**Fillauer LLC**

2710 Amnicola Highway  
Chattanooga, TN 37406  
423.624.0946



**Fillauer Europe**

Kung Hans väg 2  
192 68 Sollentuna, Sweden  
+46 (0)8 505 332 00



© 2021 Fillauer LLC  
M091/11-03-21/Rev.1