

A white line drawing of the AllPro XTS device is positioned on the left side of the cover. It features a cylindrical upper section with a top cap, a middle section with a horizontal band, and a lower section with a tapered bottom. A long, thin tube extends from the side of the middle section, curving downwards and ending in a nozzle-like tip. The drawing is set against a dark teal background.

AllPro XTS

Product Manual

Fillauer®

Contents

Intended Use.....	4
Warnings and Precautions	6
Alignment (Specifications & Preparations Before Use).....	7
Foot Shell and Spectra Sock (Consumable Components).....	12
Compatibility.....	13
Disposal / Waste Handling	13
Warranty	13
User Instructions	14
Serious Incidents	15



To see other language options, visit [fillauer.com](https://www.fillauer.com).

Intended Use

The AllPro XTS prosthetic foot is intended for use in lower extremity prostheses. The foot uses a carbon C-spring pylon (available in two heights) to maximize energy storage and release during gait, similar to a “running blade”. It has a special wave spring foot plate for shock absorption and terrain compliance at heel strike. This foot is intended for patients throughout the K3 and K4 spectrum with performance that accommodates daily living to competition level energy return with the ability to stop and turn that only comes with a heel. It is also an exceptional walking foot for moderate to strong users and provides vertical shock and torsion features. The shock and torsion reducing XTS module’s elastomer bumper provides adjustability to tune the device to the patient’s preference. Each of the different stiffness bumpers can be replaced or exchanged in the field to fine tune the amputee’s experience. The AllPro XTS bridges the gap between everyday foot and sport specific prosthesis in a single device.

Indications

- Moderate to very high activity transtibial or transfemoral amputees as defined by functional K3 and K4 activity levels
- Unilateral or bilateral patients
- Patients that would benefit from high energy return
- Patients that would benefit from shock absorption
- Patients weighing up to 275 lbs. (125 kg)

Contraindications

- Patients weighing over 275 lbs. (125 kg)
- Build height below 6.4 inches (15.2 cm)





The device is intended for single patient use only.

Performance Characteristics

- Patient weight: Up to 275 lbs. (125 kg)
- Foot build height and weight (26 cm, Category C):
 - 6.4-inch model: 1.6 lbs. (728 g)
 - 8.4-inch model: 1.7 lbs. (789 g)
- Functional level: K3 – K4
- Primary Materials: Carbon Composite, Aluminum, Polyurethane, and Stainless Steel
- Durable: meets ISO-22675 standard
- Waterproof: The foot unit is waterproof to 1 meter. See additional information below.

Parts and Accessories

Description	Part Number
Sealing Boot	229-40-0008
Lower Perch with Pins and Lower Bearing	229-10-0003
Upper O-ring with Silicone Super Lube	229-10-0005
Lower O-ring with Silicone Super Lube	229-10-0006
Closure Nut	229-30-0007

Description	Color	Part Number
Soft Bumper		229-40-0030
Medium-Soft Bumper		229-40-0040
Medium Bumper		229-40-0050
Medium-Firm Bumper		229-40-0060
Firm Bumper		229-40-0070
Closure-Nut Spanner Wrench		229-2T-0002

Pre-installed Bumpers

22 cm	23 cm	24 cm	25 cm	26 cm	27 cm	28 cm	29 cm	30 cm
22-A2	23-A2	24-A2	25-B4	26-B4				
22-A3	23-A3	24-A3	25-B4	26-B4	27-C6	28-C6		
22-B4	23-B4	24-B4	25-B4	26-B4	27-C6	28-C6	29-D7	30-D7
22-B4	23-B4	24-B4	25-C5	26-C5	27-C6	28-C6	29-D7	30-D7
22-C5	23-C5	24-C5	25-C5	26-C5	27-D7	28-D7	29-D7	30-D7
22-C5	23-C5	24-C5	25-D6	26-D6	27-D7	28-D7	29-E8	30-E8
			25-D6	26-D6	27-E8	28-E8	29-E8	30-E8
			25-E7	26-E7	27-E8	28-E8	29-F9	30-F9

Storage and Handling

It is recommended that prosthetic feet are stored between -5° and 50°C in a clean, dry environment away from harsh chemicals (chlorine, acids, acetone, etc.).

Warnings and Precautions



CAUTION: Fillauer has tested (ISO 10328) and recommends the use of standard, adult, endoskeletal components from Fillauer with all Fillauer feet. Components from other manufacturers may or may not be compatible. Failure due to use of other manufacturer's products is not covered under warranty.



CAUTION: Abnormal or improper environmental conditions will lead to malfunctioning and damage of the prosthesis and is not covered under the warranty of the device. This prosthetic/orthotic component must not be subjected to dust/debris, liquids other than fresh water, abrasives, vibration, activities which would damage the biological limb, or prolonged, extreme temperatures (< -5 °C or > 50 °C). Do not allow debris or liquids to remain in the prosthesis and its components during use. Rinse the foot with fresh water and dry immediately after exposure.



CAUTION: The foot unit is waterproof to 1 meter. However, if the foot is submerged, the foot and foot shell should be rinsed with fresh water and dried immediately to remove salt, chlorine, or debris. The foot shell and sock will experience significant deterioration if not allowed to fully dry before return to normal use and are not covered under warranty for this failure.



CAUTION: The closure nut must be torqued to 44 ft.-lbs. (60 N·m) prior to use if removed for any reason during the fitting. Under no circumstances apply any Loctite.



NOTICE: The foot should be inspected by the clinician every six months for signs of abnormal wear and to assure that the attachment/alignment screws are secure.



NOTICE: The foot stiffness is based on weight and activity level. Please provide accurate patient information so that the appropriate foot may be selected.



NOTICE: Attachment, alignment, and delivery of the foot must be performed by or under the direct supervision of a qualified prosthetist. Any adjustment or modifications should be done by the clinician and not by the user.



NOTICE: If any serious incidents occur in relation to the usage of the device, contact your Fillauer Representative and the appropriate authority in your country.

Alignment (Specifications & Preparations Before Use)

Proximal attachment

Attachment of the foot may be achieved via the proximal pyramid to any ISO 10328 compliant, Fillauer or equal, standard adult pyramid receiver. Torque all set screws to the setting specified by the manufacturer of the pyramid receiver. For Fillauer components, this is 15 N·m. Proper thread locker must be used for final delivery per the component manufacturers specifications.

Static Alignment—Sagittal Plane

Before aligning, the initial heel height should be established. Using the adapter surface for reference, the AllPro employs a 2° posterior lean (Figure 2) with a 3/8 inch (10 mm) heel block to preload the anterior keel. When the patient is weight bearing, the adapter surface should settle to a neutral or level position.

Transtibial Frontal Plane Alignment

A plum line from the bisection of the socket at the proximal brim in the frontal and sagittal plane should bisect the ankle pyramid (Figure 2). The foot may be slightly inset, 1 – 12 mm, depending on the limb length. Most runners prefer a wider base of support with the foot slightly lateral to the distal bisection 7 – 13 mm. The longitudinal axis of the foot will be externally rotated approximately 5 – 8° by aligning the medial border of the foot with the line of progression.

Transfemoral Static Bench Alignment

Alignment at the transfemoral level should be consistent with the instructions provided by the manufacturer of the prosthetic knee in use.

Figure 2

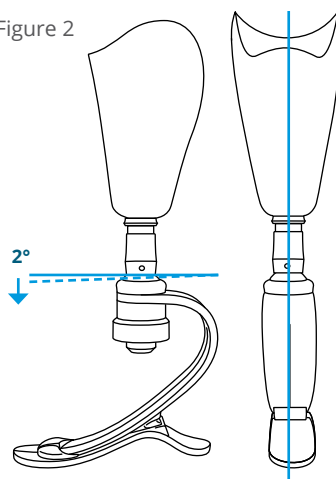

Dynamic Alignment

It is important to align the prosthesis so that the anterior keel is loaded sufficiently to provide dynamic response late in stance. Some compression of the C-spring is desirable for optimal performance and foot deflection may be more noticeable during dynamic alignment. Patient feedback during this process is essential. Adjustments of the plantar/dorsiflexion angles will help the patient achieve a smooth transition from heel to toe.

1. Check for smoothness of gait and ground contact throughout the stance phase of gait.
2. If the heel rollover is delayed from heel strike to midstance, or the heel compression is too great, dorsiflexion of foot may correct this problem. It is also possible to replace the heel bumper with the firmer, 60A bumper supplied with the foot. See bumper installation instructions.
3. If the heel rollover is too rapid from heel strike to midstance, or the heel is too hard, plantarflexion of the foot may solve this problem. Ensure that the softer bumper is installed before making any angular adjustments.
4. If the rollover is too rapid from midstance to toe loading, increased plantarflexion may be required.
5. If the rollover from midstance to toe loading is delayed, dorsiflexion may be indicated.
6. Check to make sure pylon is vertical in the frontal plane at midstance. This angulation will be done by moving the bracket, so extra time spent in bench alignment to properly match the patient's current angulation is advised.
7. Torsional resistance, range of motion and vertical shock can be adjusted at this time or later to meet the individual user's preferences for performance (softer or firmer).

If a smooth stance phase of gait cannot be achieved, contact Fillauer for additional assistance

Heel Bumper Installation

The foot is supplied with two heel bumpers: 40A durometer is standard and pre-installed. If desired, the "Firm" bumper (60A) can be installed to stiffen the heel performance.

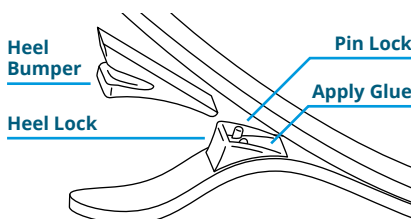

Figure 2

1. Pull the pylon and foot plate apart. Insert a piece of plastic to hold parts open.
2. Remove the Heel Bumper by pulling it up and away from the heel lock.
3. Install the new bumper and ensure the Lock Pins engage the Heel Bumper properly.
4. When the desired bumper density is determined, remove the bumper, and apply Superglue to the Heel lock and reinstall the bumper.

Changing the Toe Stiffness

The toe stiffness is pre-determined by the load category of the anterior spring members. This stiffness can be dynamically adjusted by changing the amount of plantar/dorsi-flexion of the foot. This adjustment increases or decreases the amount of anterior support during gait.

If a smooth stance phase of gait cannot be achieved, contact Fillauer for additional assistance.

Bumper Replacement Procedure



NOTICE: The bumper replacement procedure requires the closure nut to be torqued to 44 ft-lbs. (60 N·m). Be sure that a torque wrench capable of 44 ft-lbs. (60 N·m) is available before beginning the bumper replacement procedure.

1. Bumper Engagement: Note the holes in the bumper match and slide over the pins in the end cap. The bumper should be fully seated in the bottom of the end cap.

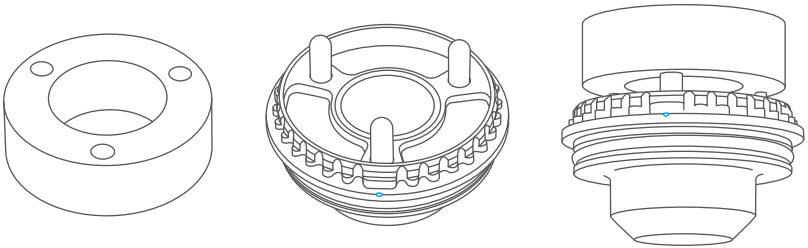

2. Fix the AllPro XTS in a vice as shown being sure to use soft jaws, a leather shim or other material to protect the foot from the jaws of the vice.

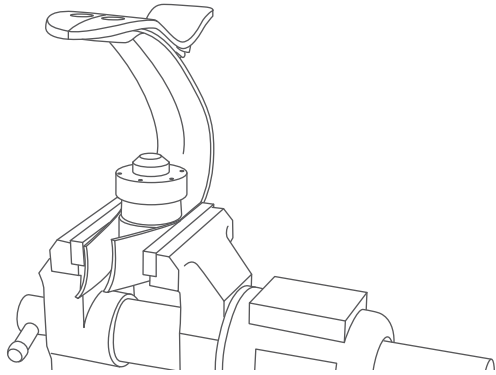

3. Insert the spanner wrench making sure the 6 pins seat fully in the closure nut. Use a $\frac{3}{8}$ in. drive ratchet wrench to loosen the closure nut. Make sure not to rotate the pyramid during assembly or disassembly.

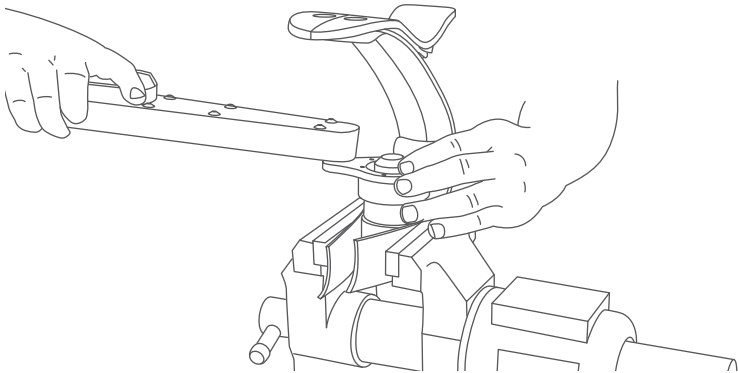

4. Once the closure nut is removed, slide off the distal cap to have access to the elastomer bumper. Remove the elastomer bumper then replace as desired for performance.

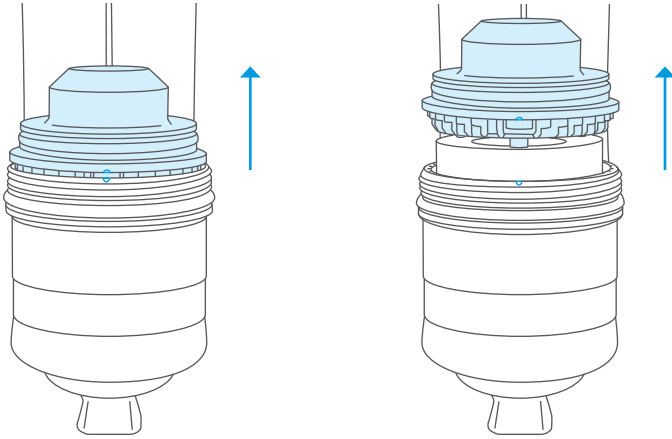

5. The replacement bumper should be well lubricated with a liberal application of the supplied Molykote 111 Compound.
6. Replace with the desired elastomer bumper—note that it must slide over all three pins and be fully seated in the end cap. Then, slide the end cap/bumper assembly back in the housing.
7. It is very important that the teeth or spline features on the distal cap mate and slide into the groove for them on the housing. There are 3 clearly identifiable spline features that are taller than the rest on the end cap and will be aligned with the housing before the rest engage. For reference, one of the 3 splines also has a small notch that will align with a notch on the housing. This engagement feature ensures that when assembled, it can only be done in the correct alignment.
8. Tighten the closure nut around the housing by hand as tight as possible. Use a torque wrench at a 90-degree orientation to the spanner wrench and torque to the mandatory 44 ft.-lb. (60 N·m). Under no circumstance should you use Loctite on these threads.

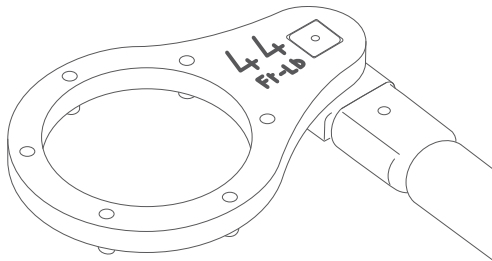

Foot Shell and Spectra Sock (Consumable Components)

The AllPro XTS uses a unique cosmetic foot shell that is flexible and durable (sold separately). Use care in the installation and removal of the foot shell to maintain its appearance and durability. Always use the shell with an internal Spectra sock (included). Never use a sharp-edged tool such as a screwdriver to install or remove the foot shell.

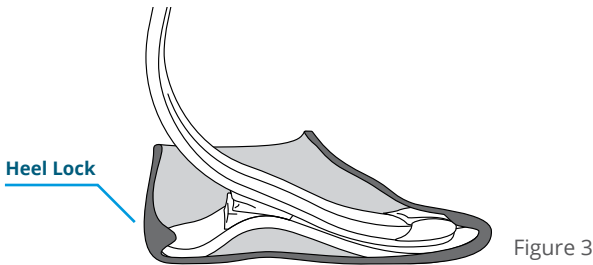

Figure 3

Installation

- Slide the provided Spectra sock onto the foot from toe to heel, pulling excess material to the ankle so that it does not bunch under the heel or toe of the foot.
- Insert the forefoot into the foot shell as far as possible. Set the heel on a supportive surface with the toe up and push the shell onto the foot until the toe is in position.
- Rotate the foot side to side to allow the foot shell to slide onto the heel.
- Push the foot shell up onto the heel or, if necessary, insert a shoehorn into the foot shell and allow the heel to slide down a shoehorn into the heel lock. The heel must lock (Figure 3) in place for proper function and safety.
- The foot shell should be inspected daily by the user and replaced by the clinician when tears or breaks are evident in the surface of the shell.
- The Spectra sock should be inspected and replaced if needed every 3 – 6 months by the prosthetist. The plantar surface of the foot should be inspected at this time and if there is excessive wear of the protective soling, it should be replaced.

Removal

- Place the foot on the bench so that the heel is hanging over the edge of the bench.
- Apply downward force to the top portion of the foot shell at the heel. The heel plate should pop out of the heel lock, allowing removal of the foot shell by hand.
- If the foot shell is too tight, a smooth-edged shoehorn may be used to disengage the heel lock.

Compatibility

Fillauer feet are appropriate for use with Fillauer or equal, ISO 10328 compliant, Endoskeletal components. A Fillauer spectra sock and foot shell should be used with this device, the fit of other manufacturers shells cannot be guaranteed.

Disposal / Waste Handling

The product must be disposed of in accordance with applicable local laws and regulations. If the product has been exposed to bacteria or other infectious agents, it must be disposed of in accordance with applicable laws and regulations for the handling of contaminated material.

All metal components may be removed and recycled at the appropriate recycling facility.

Warranty

- 36 months from date of patient fitting
- Foot Shell (sold separately): 6 months from date of patient fitting

User Instructions

The providing health care professional must review the following information directly with the user.

Care and Maintenance



WARNING: If the foot performance changes or it begins to make noise, the patient should immediately contact his or her practitioner. **These things may be as sign of a failure of the foot or other part of the prosthesis that could result in a fall or other serious injury.**



CAUTION: Attachment, alignment, and delivery of the foot must be performed by or under the direct supervision of a qualified prosthetist. Any adjustment or modifications should be done by the clinician and not by the user.



CAUTION: The foot should be inspected by the clinician every six months for signs of abnormal wear and to assure that the attachment/alignment screws are secure.



CAUTION: The foot is waterproof to 1 meter. However, if the foot is submerged, the foot and foot shell should be rinsed with fresh water and dried immediately to remove salt, chlorine, or debris.



CAUTION: The foot shell is designed to provide realistic appearance and maximum performance of the AllPro. The life of the foot shell will depend on level of activity and degree to which it is protected from wear and damage with socks and shoes. Socks and shoes should be worn at all times and should be allowed to dry fully after exposure to water to prevent damage to the shell.



CAUTION: Patients should inspect the shell daily for signs of cracks or holes and for the presence of sand or other debris. If the foot shell shows signs of failure, it should be replaced as soon as possible to prevent damage to the carbon fiber and soling materials. If debris is present, the foot and shell should be rinsed and allowed too fully dry.



CAUTION: The foot shell may also be cleaned with a soft cloth and a soap and water solution or with rubbing alcohol (70%). Do not use acetone. It will damage the foot shell.

Serious Incidents

In the unlikely event a serious incident occurs in relation to the use of the device, users should seek immediate medical help and contact their prosthetist, local competent authority and Fillauer at the earliest possible convenience. Clinicians should at any time contact their local Fillauer representative and local competent authority immediately in the event of any device failure.

Fillauer®

www.fillauer.com



Fillauer LLC

2710 Amnicola Highway
Chattanooga, TN 37406
423.624.0946



Fillauer Europe

Kung Hans väg 2
192 68 Sollentuna, Sweden
+46 (0)8 505 332 00



© 2023 Fillauer LLC
M094/04-05-22/02-03-23/Rev.2